

LINJE~~POS=TRUNC REGULATO- RER

DCN500 AG 50-6-450



- Linje regulator - Single scenen
- Montering på ledningsnettet
- Egnet for industrigasser
- Laget av forniklet messing

Industrial Process

Domains of applications

Designed for implementation of:
industrigasser, metan

Specifications

Maximal inlet pressure at 15°C 50 bar
Outlet Pressure..... 0,8 til 6 bar
Nominal nitrogen flow 450 Nm³/h*
Driftstemperatur: -20 ° C til + 50 ° C.
* Nominell tilførsel av nitrogen ved 15 ° C.

Materials

Body Forniklet messing
Seat Messing
Main valve..... Brass EPDM belagt
Diaphragm NBR
Filter Monel®
Kobber legering mekanisme, Ø
Pressure gauge 50mm
Seal Kobber, EPDM

Monel® er et varemerke for Special Metals Corporation.

Dimensions

- Length (L) : 94 mm
- Height (H) : 221 mm
- Depth (D) : 127 mm
- Ø1 : 50 mm
- Net weight : 2.5 kg

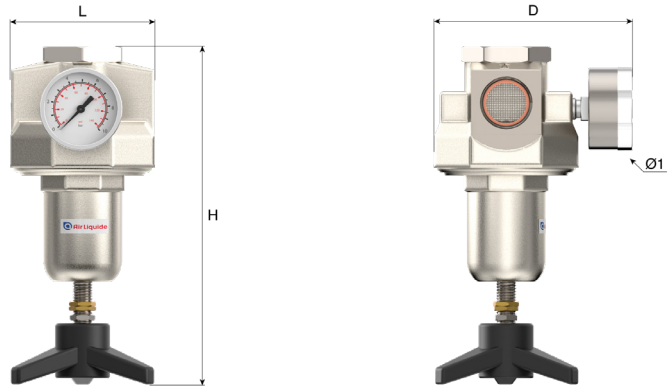

Operating instructions

OP 212 - DCn500

Connection

- Inlet connection: En innløpsport G 3/4" hunn
- Outlet connection: En utløpsport G 3/4" hunn

Flow curve

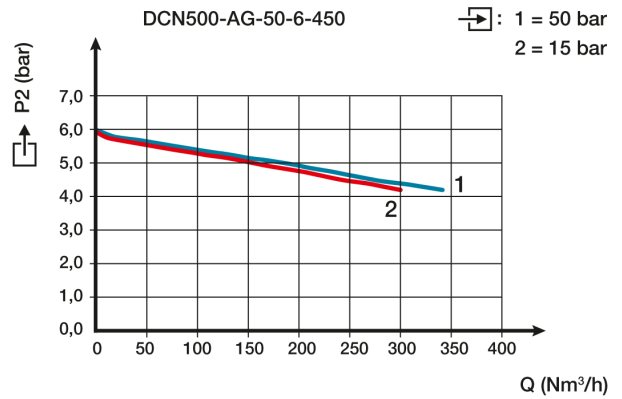

Products

Product Number	Short Designation	Gas	Inlet Pressure	Outlet Pressure	Flow	Inlet Fitting	Outlet Fitting	Material
153737	REG DCn500 AG 50-6-450	Luft, CO2, inerte gasser, H2, O2	50 bar	6 bar	450 Nm³/h	G 3/4 BSPP F	G 3/4 BSPP F	Messing

Spare parts

Product Number	Long designation
153737	18525 Pressure Gauge 0-10 Bar Ø 50mm Back entry G1/4 for DCn100, 300, 500/2 and 800/2 Brass-Cr
	160144 KIT Inlet / Outlet for DCn100 (Inlet Seal + Filter)